



SilentPACK

The extremely silent industrial multi-cylinder Diesel engine

2L41C • 3L41C • 4L41C

15.0 - 56.0 kW • 20.4 - 76.2 HP

**MOTORENFABRIK HATZ
D-94099 RUHSTORF • GERMANY**

Tel: 0 85 31 / 319-0 • Fax: 31 94 18
<http://www.hatz-diesel.de>
 eMail: marketing@hatz-diesel.de

5 / 569 ENG Printed in Germany
 Modifications, which serve the technical improvements, are reserved.



Design

- Aircooled 2-, 3- and 4-cylinder fourstroke Diesel engines, modular design.
- Grey cast iron crankcase, vertical in-line cylinders.
- Crankshaft and conrod running on shell-bearing.
- Individual cylinders (grey cast iron), individual cylinder-heads (light metall) and individual injection pumps.
- Dismantling of piston and conrod possible in upwards direction.
- Direct injection with multi-hole nozzle.
- Valve control via camshaft, tappets, rocker and pushrod.
- Separate camshaft for drive of injection pump with centrifugal variable speed governor and automatic injection timer.
- Pressure feed lubrication with gear pump. Oilcooler and filter in main flow.
- Axial-type blower fan with incorporated alternator.
- The Silent Pack is an engine of family L with noise-proof capsule.
- The easy accessibility of maintenance and operating points remains unchanged also with the Silent Pack engines.

Characteristics

- The Diesel engine ready for installation and operation.
- All-Purpose industrial Diesel engines.
- Extremely low fuel- and oil consumption.
- Exhaust emission well below all valid limits for operating machines in EC, USA and Japan.
- Robust, and long life-engine.
- Extensive parts interchangeability due to modular system.
- Low repair cost due to individual cylinders, individual cylinder-heads and individual injection-pumps.
- Unusual reliability because of:
 - Automatic belt control
 - Automatic extra fuel device
 - Dry-type airfilter, protected against severe contamination.
- Easy to service because of:
 - Automatic injection pump bleeding
 - Operating and maintenance points at one engine side only
 - Hydraulic belt tensioner
- The most silent industrial Diesel engine of its class.
- The capsule reduces the engine noise by 90%.
- Noisy auxiliary drives can be incorporated in the capsule.
- The capsule is smaller and more handy than other noise-reduction engine cowlings and it is just as efficient as expensive and heavy encapsulations of machines.
- The exhaust silencer is integrated into contour of the capsule.

Engine type	Dimensions (mm)		
	Lenght	Width	Height
2L41C	719	596	748
3L41C	854	596	748
4L41C	989	596	748

Technical data		C	C	C
Number of cylinders		2	3	4
Bore x Stroke	mm	102 x 105	102 x 105	102 x 105
	inches	4.02 x 4.13	4.02 x 4.13	4.02 x 4.13
Displacement	l	1.716	2.574	3.432
	cu.in.	104.7	157.0	209.4
Mean piston speed at 3000 r.p.m.	m/s	10.5	10.5	10.5
	ft/s	2067	2067	2067
Compression ratio			18.7	
Lub. oil consumption		approx.. 0.2% of fuel consumption, related to full load		
Lub. oil capacity max. / min.	l	4.7 / 2.8	7.8 / 4.7	15.0 / 11.3
	US qts	5.0 / 3.0	8.2 / 5.0	15.9 / 11.9
Speed control	Lowest idle speed	approx. 800 r.p.m.		
	Stat. speed droop	approx.. 5% at 3000 r.p.m.		

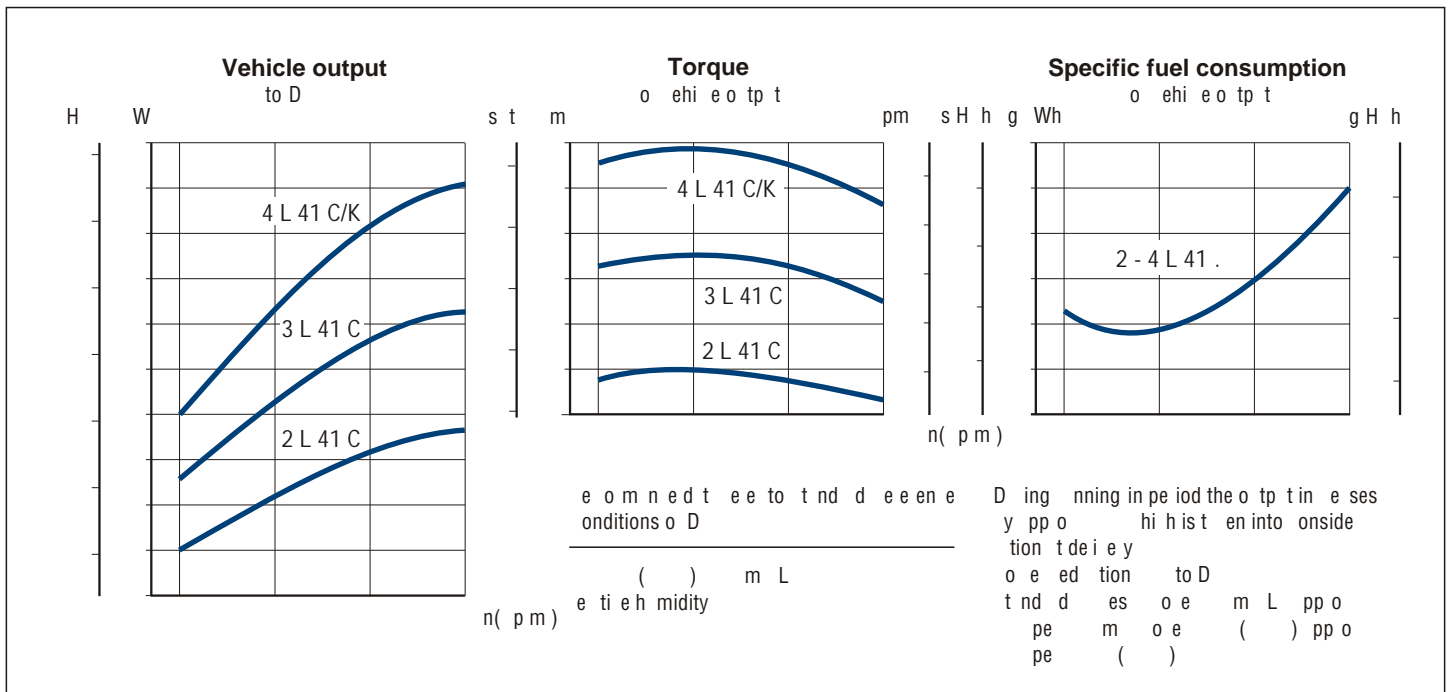

Performance		C	C	C				
	Hatz-Stand	r.p.m.	kW	HP	kW	HP	kW	HP
ISO net brake fuel stop power (IFN) for strongly intermittent load acc. to DIN ISO 3046.	B _{SI}	3000	25.7	35.0	38.8	52.8	51.5	70.0
		2600	24.5	33.3	37.1	50.5	48.5	66.0
		2300	23.5	32.0	35.9	48.8	47.0	63.9
		2000	20.9	28.4	31.2	42.4	41.0	55.8
		1800	18.7	25.4	28.0	38.1	37.0	50.3
		1500	15.0	20.4	22.9	31.1	30.0	40.8
ISO net brake fuel stop power (IFN) for intermittent load acc. to DIN ISO 3046.	B	3000	24.4	33.2	36.7	49.9	48.8	66.4
		2600	23.2	31.6	35.2	47.9	45.9	62.4
		2300	23.5	32.0	35.9	48.8	47.0	63.9
		2000	20.9	28.4	31.2	42.4	41.0	55.8
		1800	18.7	25.4	28.0	38.1	37.0	50.3
		1500	15.0	20.4	22.9	31.1	30.0	40.8
ISO-standard power (ICXN) (10% overload permissible) and ISO-standard fuel stop power (no overload permissible) acc. to DIN ISO 3046. For constant speed and constant load (ICFN).	S	3000	22.0	29.9	33.0	44.9	43.9	59.7
		2600	20.9	28.4	31.7	43.1	41.3	56.2
		2300	21.2	28.8	32.3	43.9	42.3	57.5
		2000	18.8	25.6	28.1	38.2	36.9	50.2
		1800	16.8	22.8	25.2	34.3	33.3	45.3
		1500	13.5	18.4	20.6	28.0	27.0	36.7

nsta ati n ata		C	C	C
Combustion air required at 3000 r.p.m. approx. ¹⁾	m ³ / min	2.6	3.9	5.2
	cu.ft./min	92	138	184
Cooling air required at 3000 r.p.m. approx. ¹⁾	m ³ / min	29	39	49
	cu.ft./min	1024	1377	1730
Permanent tilting	max. degrees	30 ^{2) 3) 4) 5)}	25 ^{2) 3) 4)} 30 ⁵⁾	25 ⁴⁾ 30 ⁵⁾ 15 ²⁾ 18 ³⁾
Moment of inertia	SAE-flywheel 8"	0.64 kgm ² (15.2 lb.ft ²)	0.65 kgm ² (15.4 lb.ft ²)	0.67 kgm ² (15.9 lb.ft ²)
	flywheel for F+S clutch	0.49 kgm ² (11.6 lb.ft ²)	0.50 kgm ² (11.9 lb.ft ²)	0.51 kgm ² (12.1 lb.ft ²)
Starter motor		12 V - 2.7 kW (3.7 HP)		24 V - 4.0 kW (5.4 HP)
Alternator charging current at 3000 / 1500 r.p.m.		14 V - 50 / 42 A		28 V - 40 / 28 A
Battery capacity	min. / max. Ah	12 V - 88 / 143 Ah		24 V - 55 / 110 Ah

1) For other r.p.m. there is a linear reduction of the air requirement

2) Applicable for flywheel up

3) Applicable for flywheel low

4) Applicable for oilfilter low

5) Applicable for oilfilter up

Permissible load on power-take-off points

max. permissible load

- Flywheel: Power-take-off axial and radial at full engine torque.
- Shaft W: Suitable for axial power-take-off, for example adaption of a hydraulic pump. Max. torque 70 Nm drive with engine speed.

max. permissible radial force

$$F1 = \frac{400\,000}{L \text{ (mm)} - 73} \text{ (N)}$$

max. permissible axial force

$$F2 = 2700 \text{ N}$$

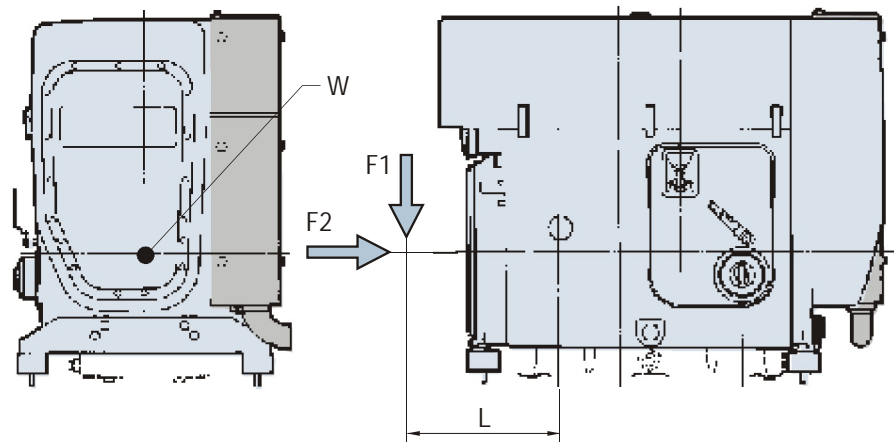

Maintenance- and operating points

For the engine to achieve its maximum life, it is essential that the engine is serviced meticulously at regular intervals.

During your first installation please make sure that easy accessibility of service and operating points is assured.

The easier the accessibility is, the sooner and more conscientious the engine will be maintained.

Please convince yourself personally that all service and operation points are easily accessible before delivering your machine to the customer.

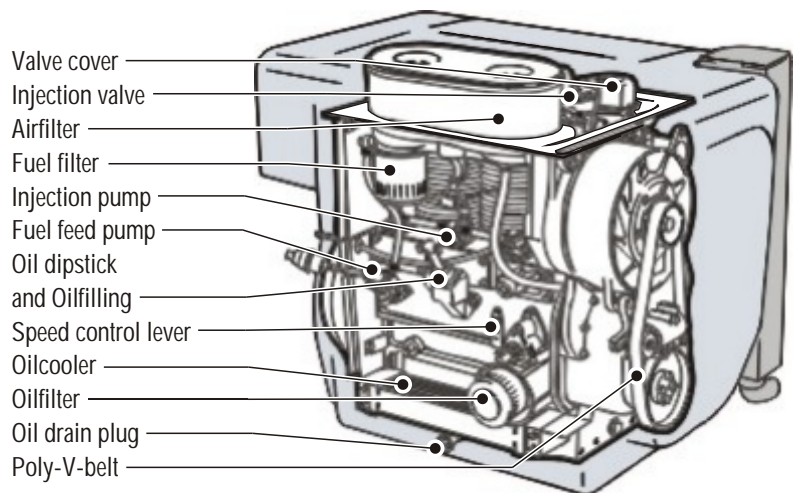

ectrica e i ent

The engine mounted components, such as starter, alternator and switches are connected to the instrument box by means of a 2 m cable harness. The engine is started and controlled from this instrument box. Instrument box and cable harness are part of the additional equipment and supplied according to the number of electrical safety features

which are required. If the engine has to be started at temperatures below - 15 °C, engine must be fitted with a pre-heating system (glow plug) (additional equipment). Further additional equipments include automatic start and stop, remote control etc.

Please ask for drawings and wiring diagrams.



er a e an ense tati n

- Power-take-off on flywheel-side (pict. 1).
- Power-take-off on governor side with engine speed, max. torque 70 Nm, radial force not permitted (pict. 2/W).
- Rotation see pict. 1 and 2.
- Engine flangeable at flywheel-side.

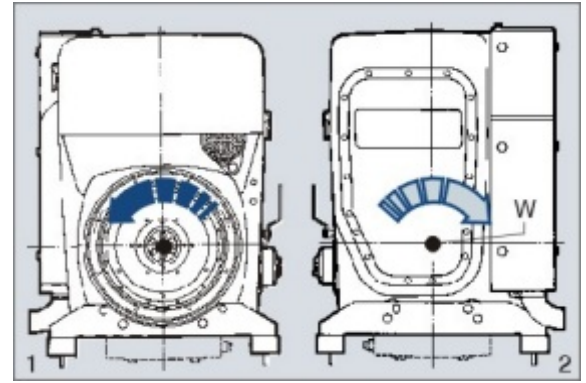

ngine Designati ns

- Execution . . . C: with capsule, with additional counter balance shaft ("U" pict. 3).
- Execution . . . K: with capsule, without additional counter balance shaft (for special applications only).

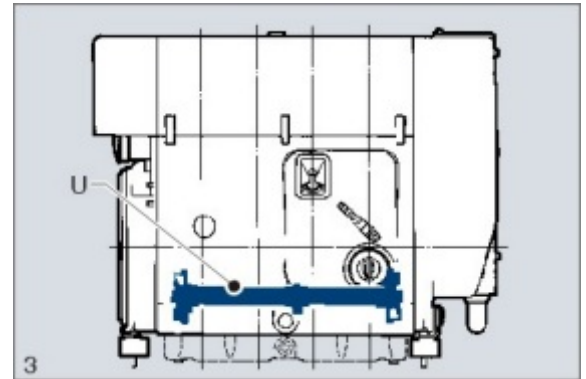

ngine ariants

- Variant XI: Engine with electric start 12 V
- Variant XIII: Engine with electric start 24 V

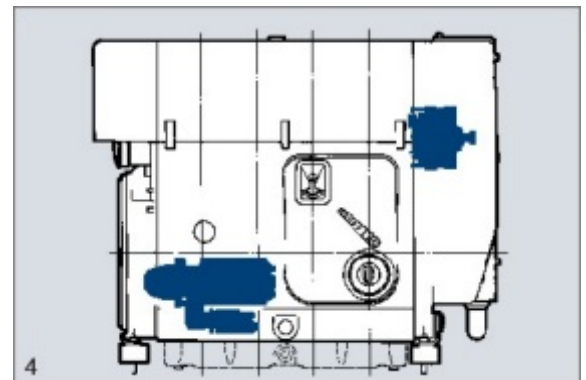

ights

Design	2L41., Var. XI, XIII		3L41., Var. XI, XIII		4L41., Var. XI, XIII	
	kg	lbs.	kg	lbs.	kg	lbs.
C	276	608	331	730	396	873
K	—	—	—	—	386	851

c e De i er ngine

Engine tested for full load on test bench. Engine fitted with blower fan, variable speed governor, injection timer, lubricating oilfilter, dry-type airfilter, hydraulic belt tensioner, automatic stop in case of belt failure, automatic injection pump bleeding, filling device for start oil, eye hook for transport of engine (only suitable to carry the engine weight). Painting in HATZ standard colours or primer.

Accessories: Tools and gasket for 1st maintenance, instruction booklet, spare parts list and "Service International".

Further equipment included in engine variants:

- Variant XI: Electric starter 12 V, 2.7 kW, alternator 14 V, 50 A, engine wiring, electric maintenance indicator for airfilter, oil pressure switch, fuel feed pump and fuel filter, exhaust elbow, engine brackets. Additional oil sump.
- Variant XIII: Same as Variant XI, however electric starter 24 V, 4.0 kW and alternator 28 V, 40 A.

iti na e i ent

Thanks to the complete programme of additional equipment engine can be adapted to the special requirements of every application. As a minimum every engine needs the "additional equipment, necessary for operation".

For selection of additional equipment see "Engine and Equipment Survey".

